

### Features

- 48Watts peak pulse power ( $t_p = 8/20\mu s$ )
- SOT-23-6 Package
- Unidirectional configurations
- Solid-state silicon-avalanche technology
- Low clamping voltage
- Low leakage current
- Low capacitance (0.3pF typical I/O to I/O)
- ESD Protection for high-speed data lines to:
  - IEC 61000-4-2  $\pm 20KV$  contact  $\pm 20KV$  air
  - IEC 61000-4-4 (EFT) 40A (5/50ns)
  - IEC 61000-4-5 (Lightning) 6A (8/20 $\mu s$ )

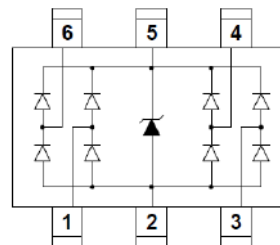

### Mechanical Data

- **Case:** SOT-23-6 (plastic package).  
Lead free; RoHS compliant; Halogen free
- **Molding Compound Flammability Rating:**  
UL 94 V-0
- **Terminals:** High temperature soldering guaranteed:  
260 °C/10 sec. at terminals

### Applications

- USB 3.0, USB 2.0, MHL
- HDMI 2.0, Display Port 1.3, eSATA
- Unified Display Interface (UDI)
- Digital Visual Interface (DVI)
- High speed serial interfaces

### Absolute Maximum Ratings

Ratings at 25 °C, ambient temperature unless otherwise specified

Parameter	Symbol	Value	Unit
Peak Pulse Power ( $T_P=8/20\mu S$ )	$P_{PP}$	48	W
ESD contact/air discharge (IEC-61000-4-2)	$V_{ESD}$	20/20	kV
Peak Pulse Current ( $t_P = 8/20\mu S$ )	$I_{PP}$	6.0	A
Junction Temperature	$T_J$	-55 to +125	°C
Storage temperature	$T_{STG}$	-55 to +150	°C

### Electrical Characteristics

( $T_A = 25\text{ °C}$  unless otherwise specified)

Parameter	Symbol	Condition	Min	Typ	Max	Unit
Reverse stand-off Voltage	$V_{RWM}$				3.3	V
Reverse Breakdown Voltage	$V_{BR}$	$I_T=1mA$	4			V
Reverse Leakage Current	$I_R$	$V_R=5V$			0.5	$\mu A$
Clamping Voltage(SURGE)	$V_C$	$I_{PP}=6A, T_P=8/20\mu s$		8	11	V
Junction Capacitance	$C_J$	$V_R=0V, f=1MHz, I/O$ to I/O		0.3		pF
	$C_J$	$V_R=0V, f=1MHz, I/O$ to GND		0.6		pF

**Typical Characteristics** ( $T_{amb} = 25\text{ }^{\circ}\text{C}$  unless otherwise specified)

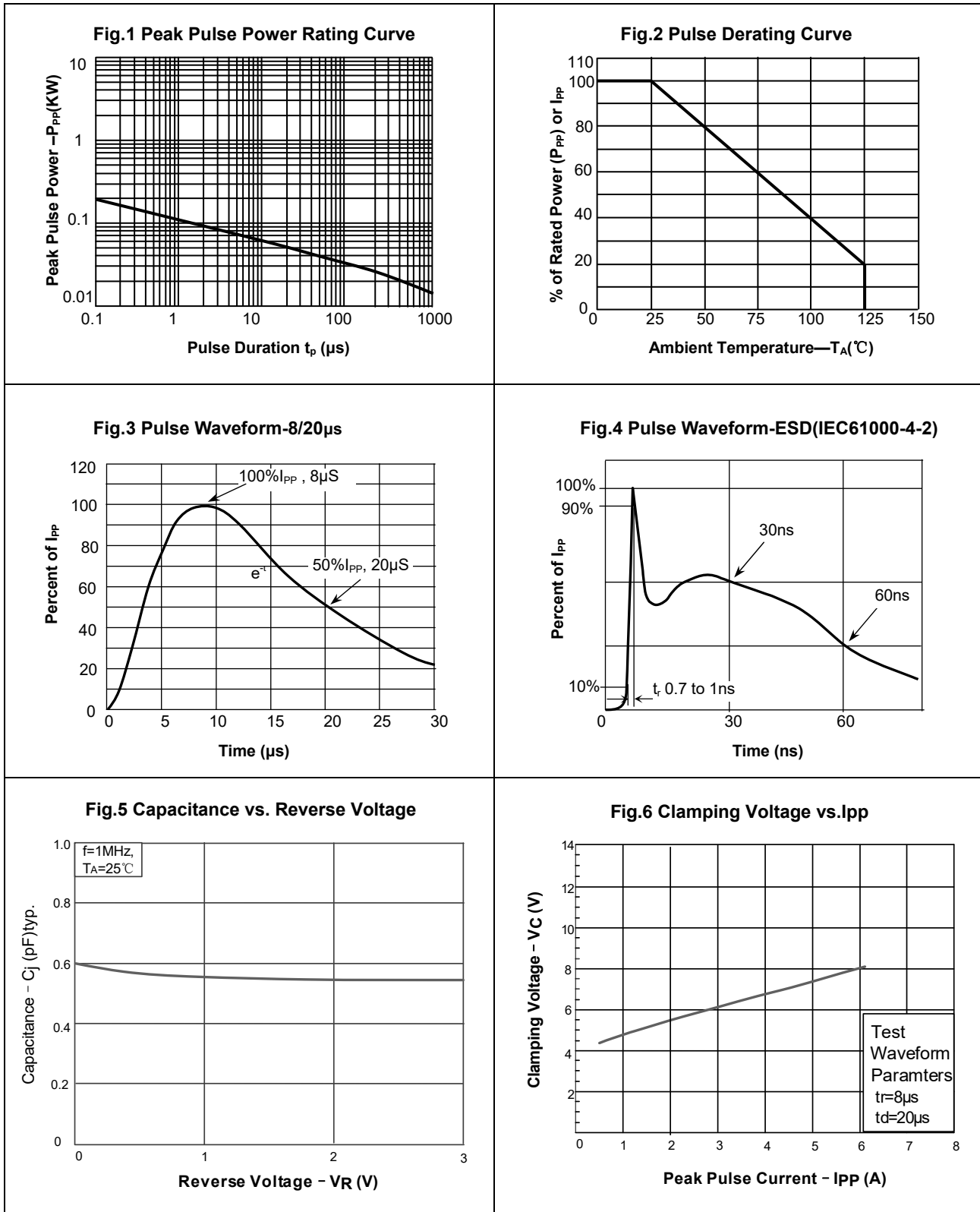

### Package Dimensions

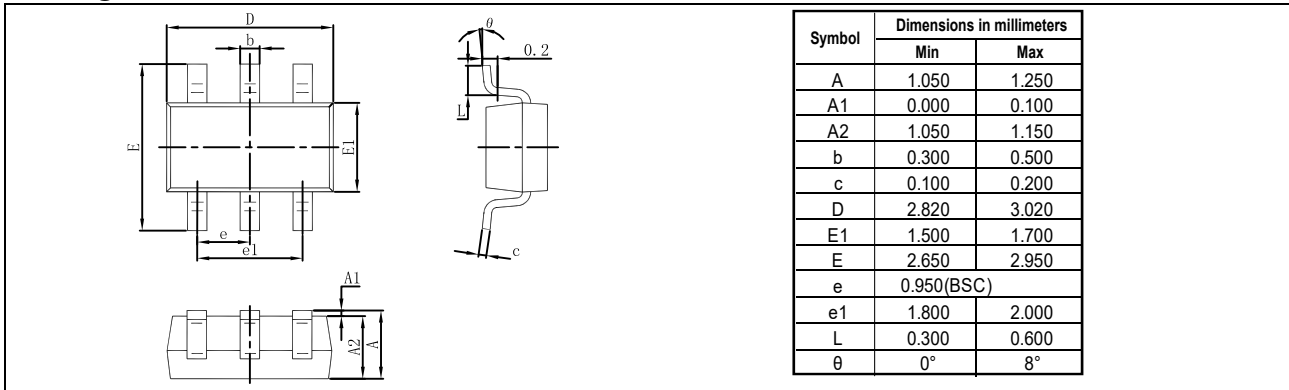

### Pad dimensions

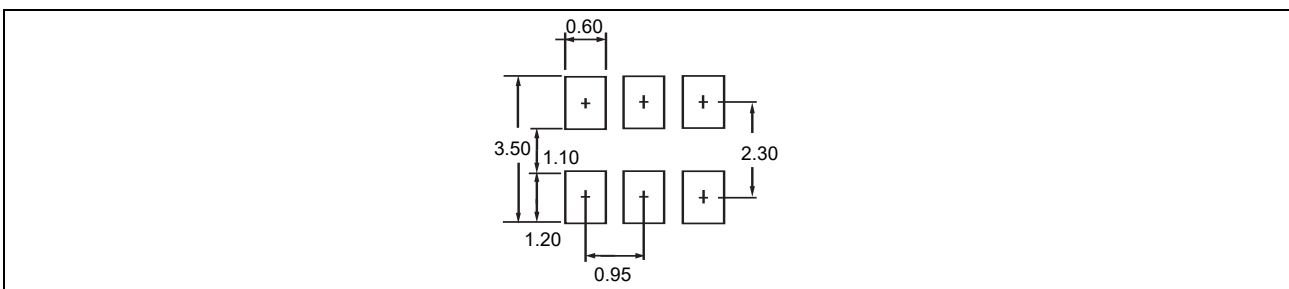

### Package information

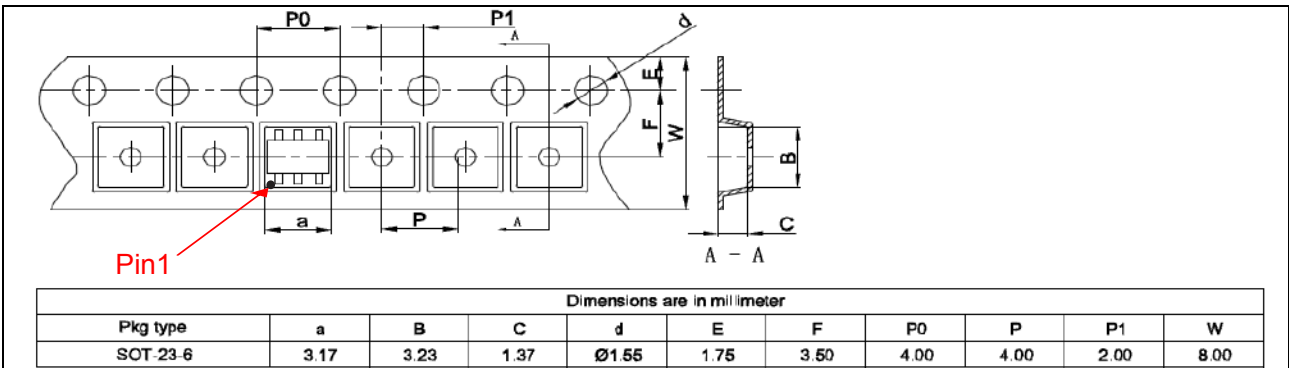

### Ordering information

Order code	Package	Packaging option	Base quantity	Packaging specification
YEUST263R06AU	SOT-23-6	Tape and reel	3000pcs / reel	EIA STD RS-481